

Ericsson Network Manager (ENM) 18 Training Program Commercial Presentation



ENM 18 Learning Levels & Areas



Technical Fundamentals

ENM Radio Access Network

ENM Core Network

ENM Transport

ENM System Admin

ENM Delta

VNF LCM in ENM

Python in ENM

FMX in ENM

Case Study : Typical Competence Flow for Operations and System Administration

Learning Levels & Areas



Technical Fundamentals

ENM Radio Access Network

ENM Core Network

ENM Transport

ENM System Admin

ENM Delta

VNF LCM in ENM

Python in ENM

FMX in ENM

Case Study : Typical Competence Flow for Operations and System Administration

Technical Fundamentals for OSS-RC and SO EM Users

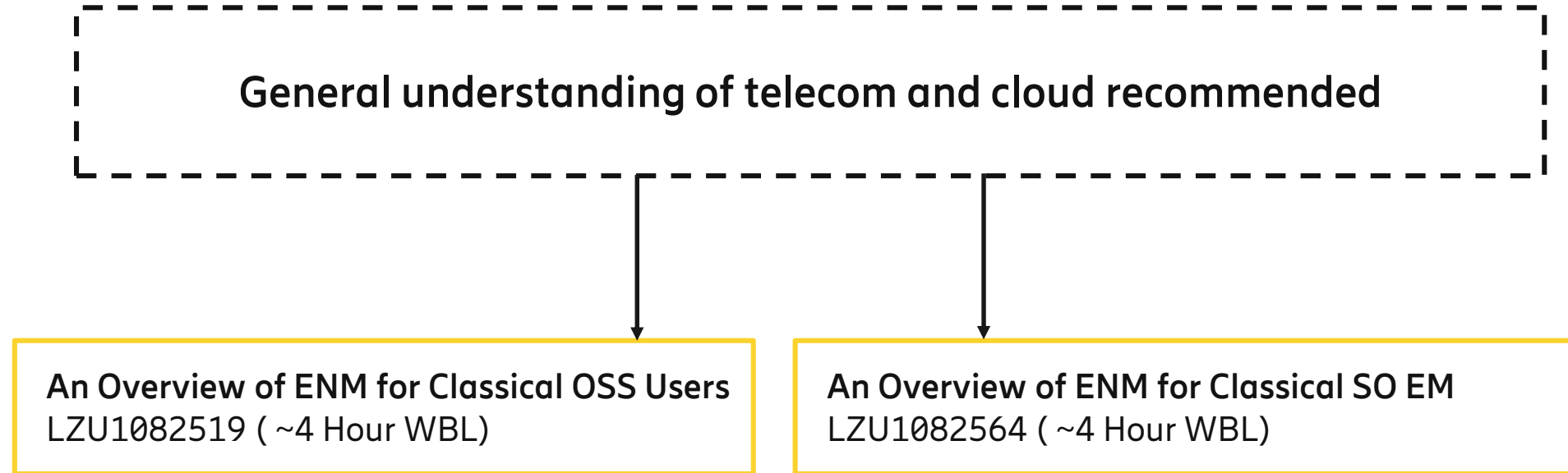

Technical Fundamentals for ENM on Cloud



General understanding of telecom, cloud and virtualization recommended

An Overview of the Ericsson Cloud Infrastructure
LZU1082558 (~1 Hour WBL) Optional

Pre-requisite

Overview of ENM Application on Cloud
LZU1082563 (~2 Hour WBL)

Learning Levels & Areas



Technical Fundamentals

ENM Radio Access Network

ENM Core Network

ENM Transport

ENM System Admin

ENM Delta

VNF LCM in ENM

Python in ENM

FMX in ENM

Case Study : Typical Competence Flow for Operations and System Administration

ENM for Radio Access Network

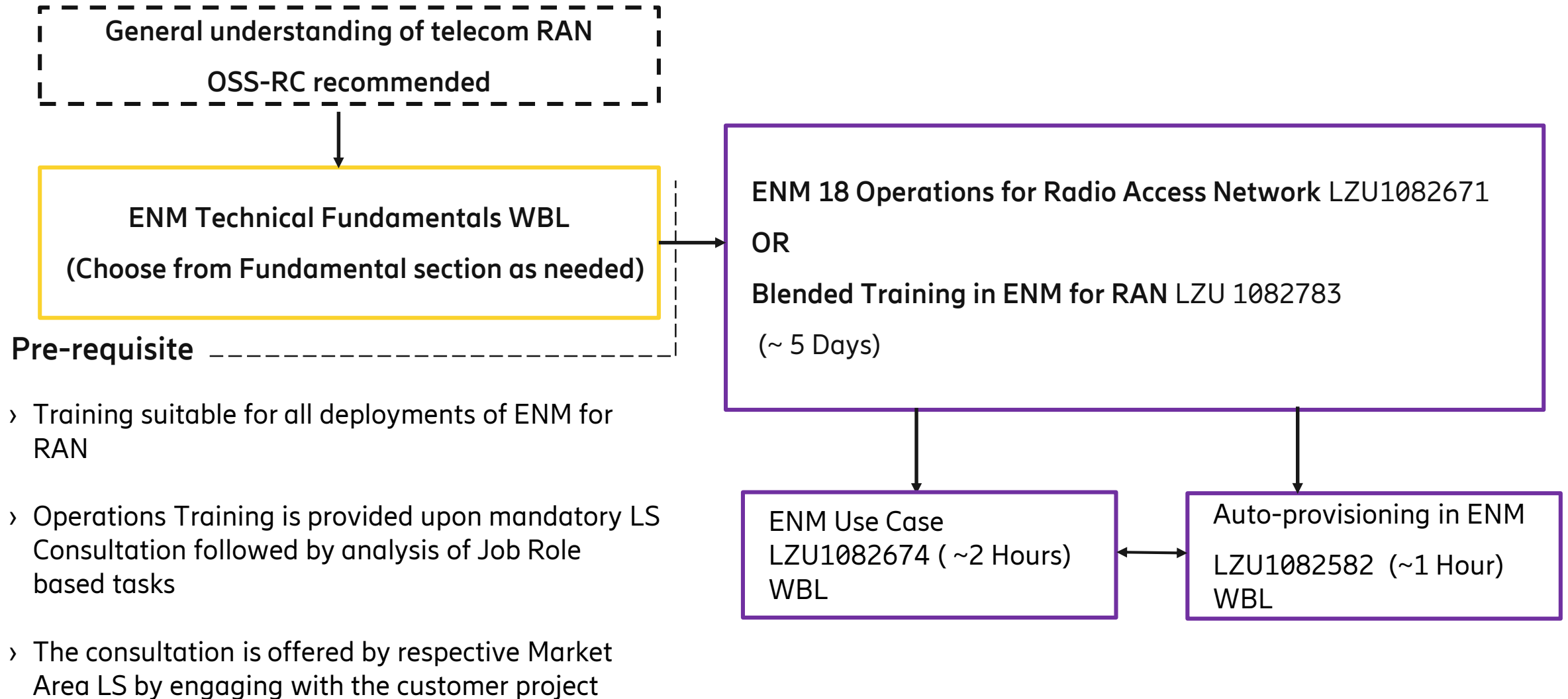

Learning Levels & Areas



Technical Fundamentals

ENM Radio Access Network

ENM Core Network

ENM Transport

ENM System Admin

ENM Delta

VNF LCM in ENM

Python in ENM

FMX in ENM

Case Study : Typical Competence Flow for Operations and System Administration

ENM for Core Network

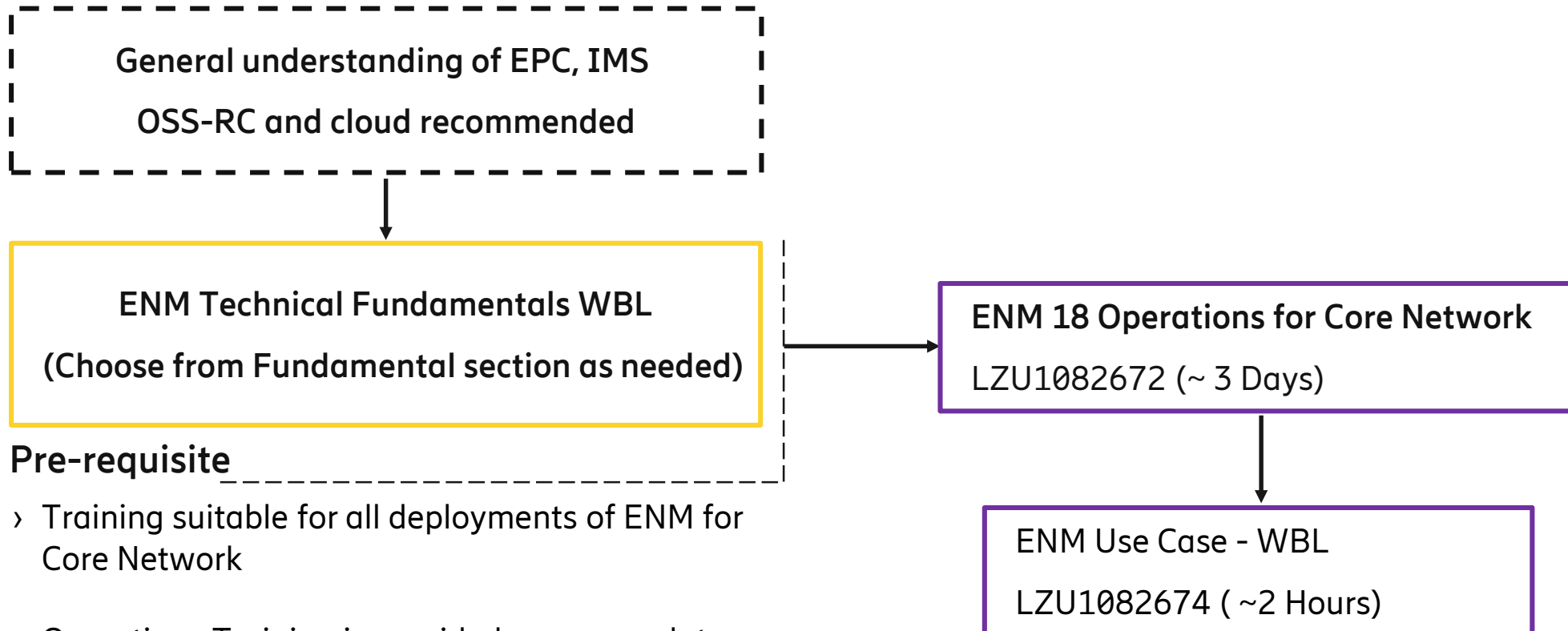

Pre-requisite

- › Training suitable for all deployments of ENM for Core Network
- › Operations Training is provided upon mandatory LS Consultation followed by analysis of Job Role based tasks
- › The consultation is offered by respective Market Area LS by engaging with the customer project

Learning Levels & Areas



Technical Fundamentals

ENM Radio Access Network

ENM Core Network

ENM Transport

ENM System Admin

ENM Delta

VNF LCM in ENM

Python in ENM

FMX in ENM

Case Study : Typical Competence Flow for Operations and System Administration

ENM for Transport Network

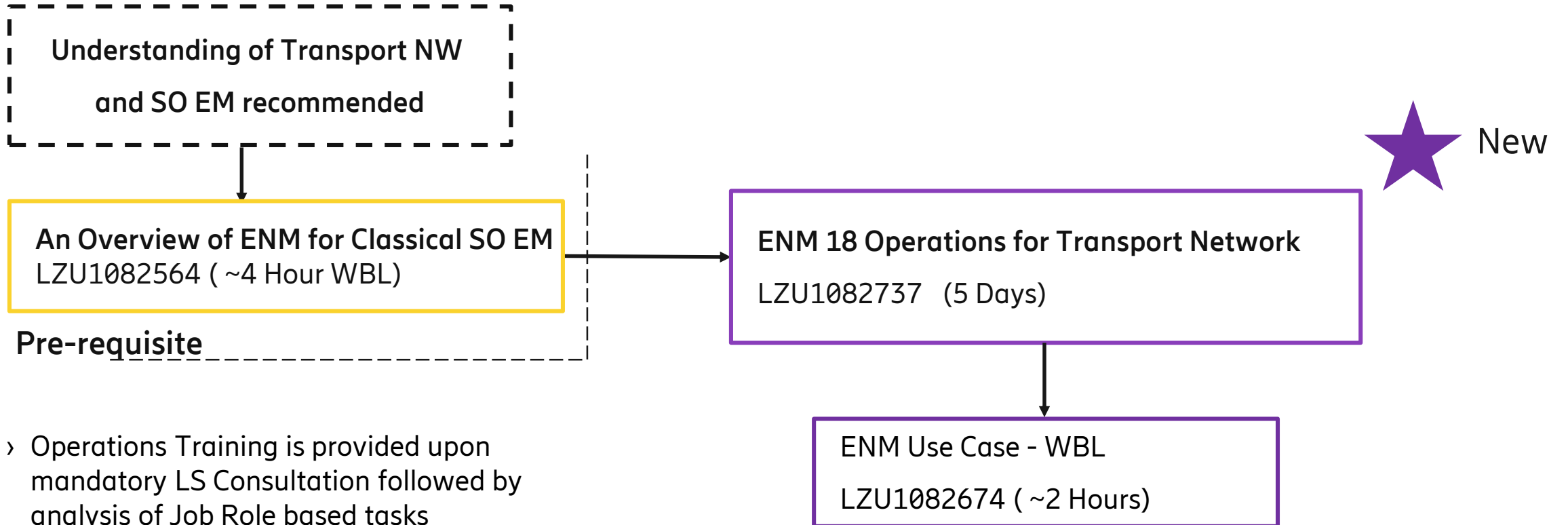

- › Operations Training is provided upon mandatory LS Consultation followed by analysis of Job Role based tasks
- › The consultation is offered by respective Market Area LS by engaging with the customer project

Learning Levels & Areas



Technical Fundamentals

ENM Radio Access Network

ENM Core Network

ENM Transport

ENM System Admin

ENM Delta

VNF LCM in ENM

Python in ENM

FMX in ENM

Case Study : Typical Competence Flow for Operations and System Administration

Python in ENM

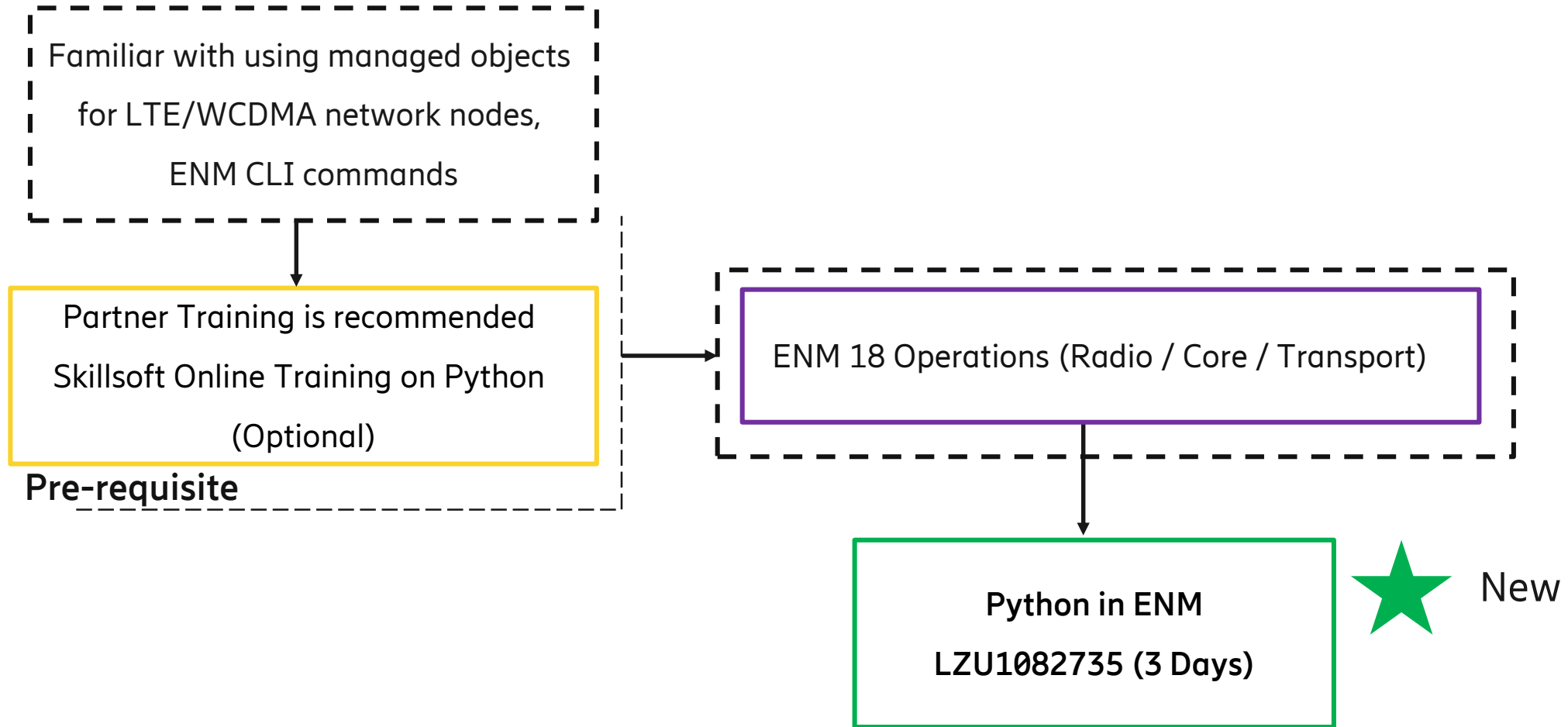

VNF LCM in ENM

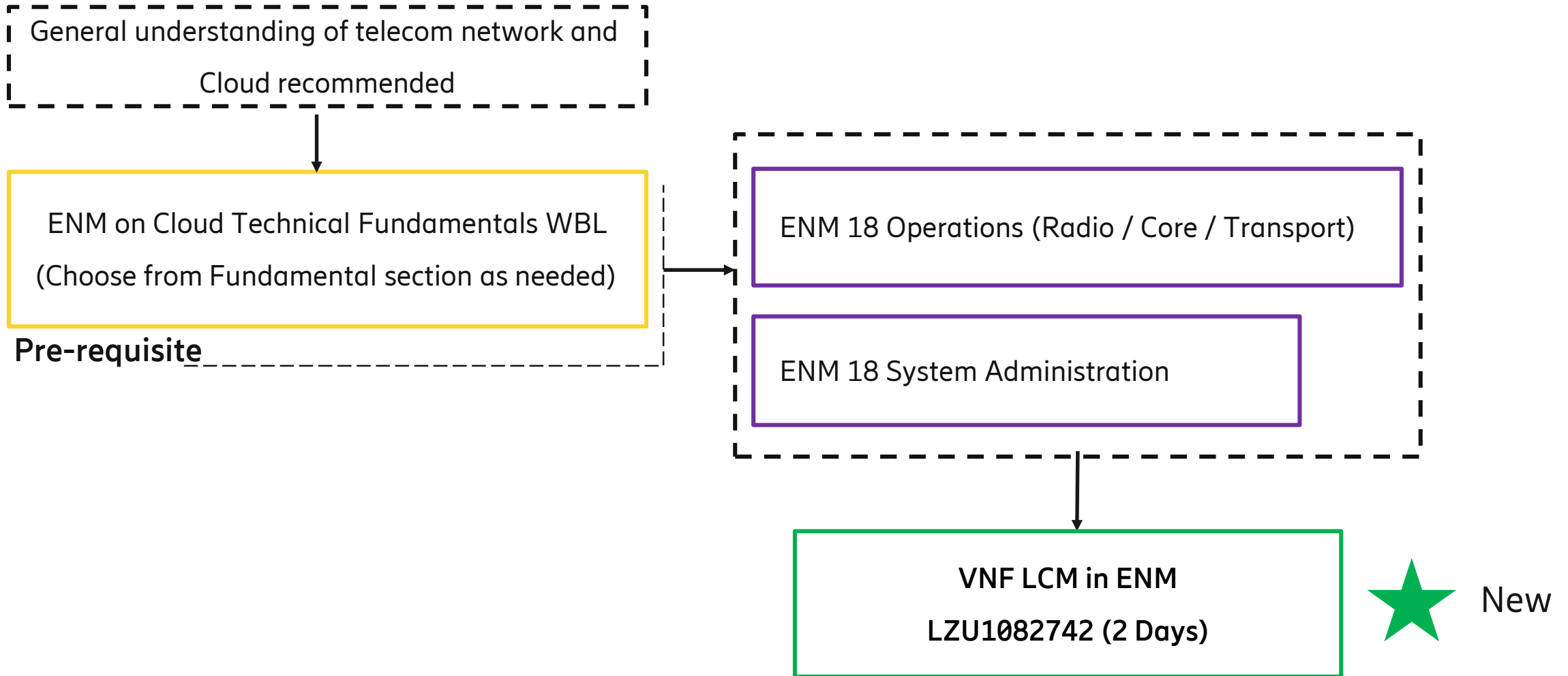

FMX in ENM

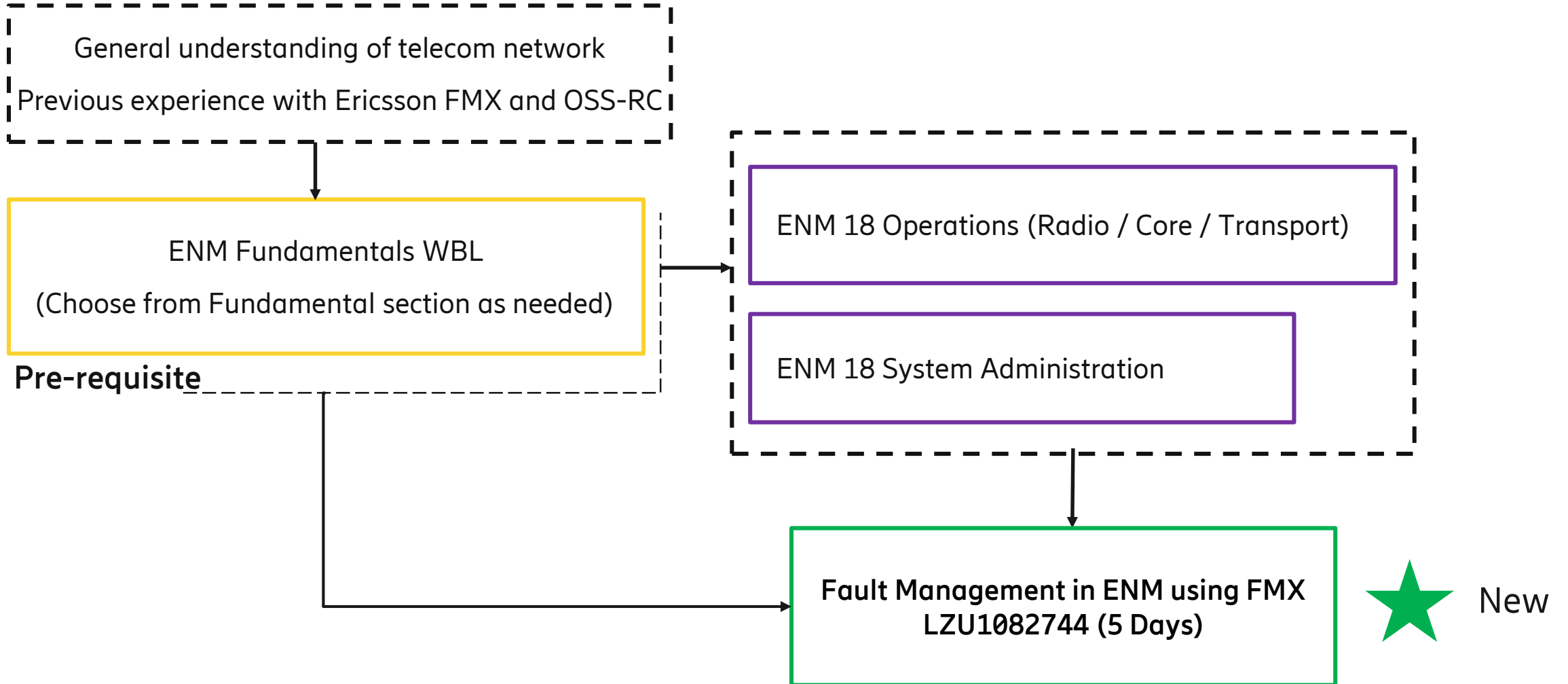

Learning Levels & Areas



Technical Fundamentals

ENM Radio Access Network

ENM Core Network

ENM Transport

ENM System Admin

ENM Delta

VNF LCM in ENM

Python in ENM

FMX in ENM

Case Study : Typical Competence Flow for Operations and System Administration

ENM System Administration

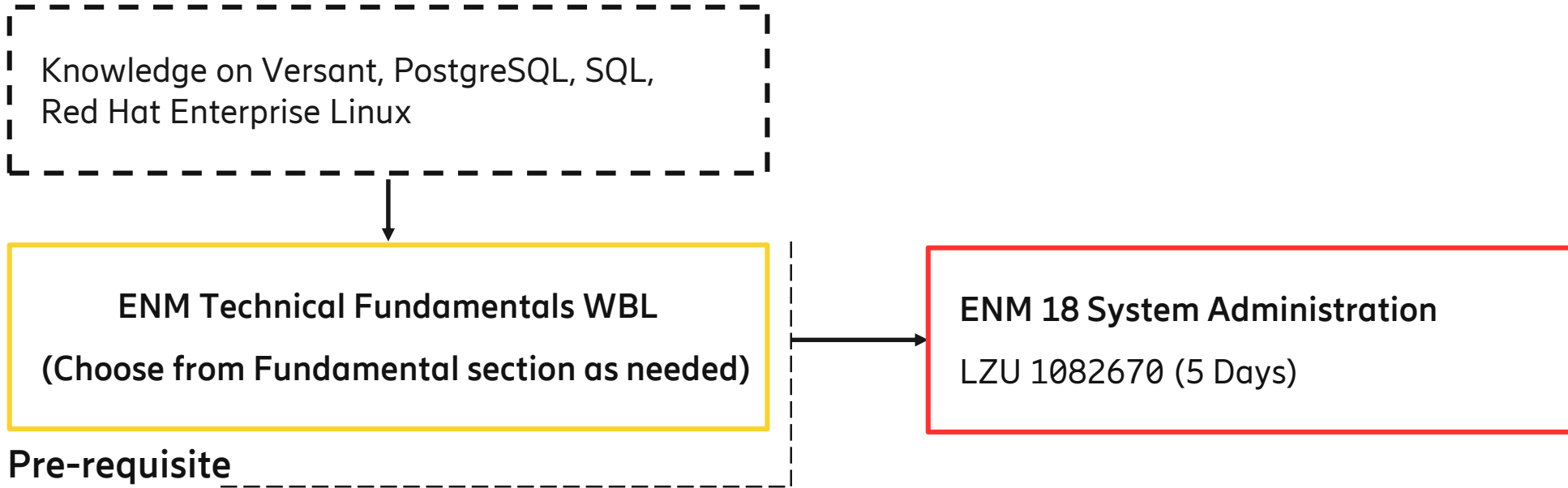

ENM Application on Cloud System Administration

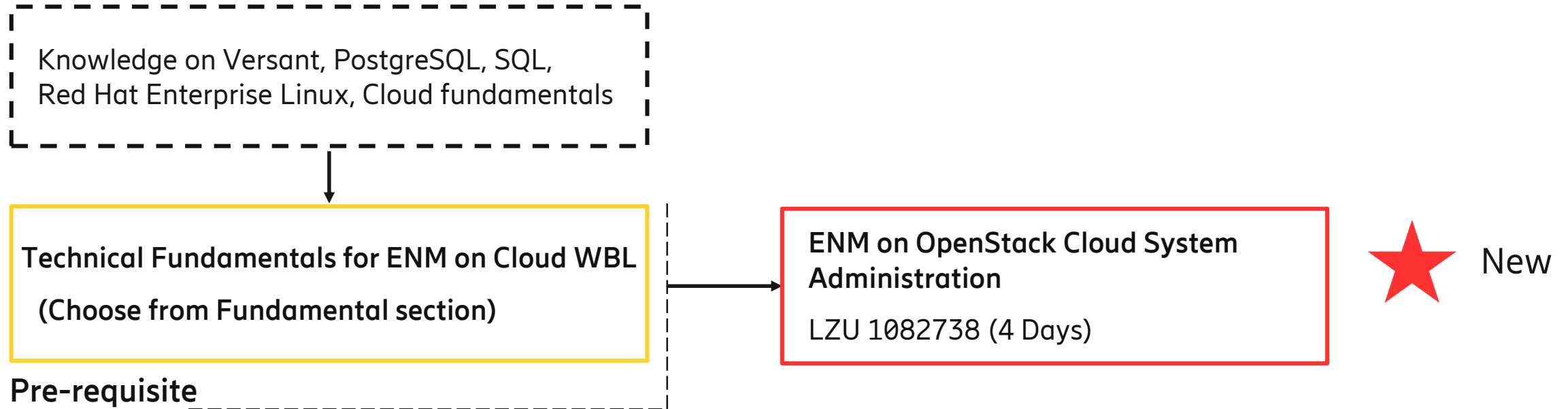

Learning Levels & Areas



Technical Fundamentals

ENM Radio Access Network

ENM Core Network

ENM Transport

ENM System Admin

ENM Delta

VNF LCM in ENM

Python in ENM

FMX in ENM

Case Study : Typical Competence Flow for Operations and System Administration

ENM Delta Training

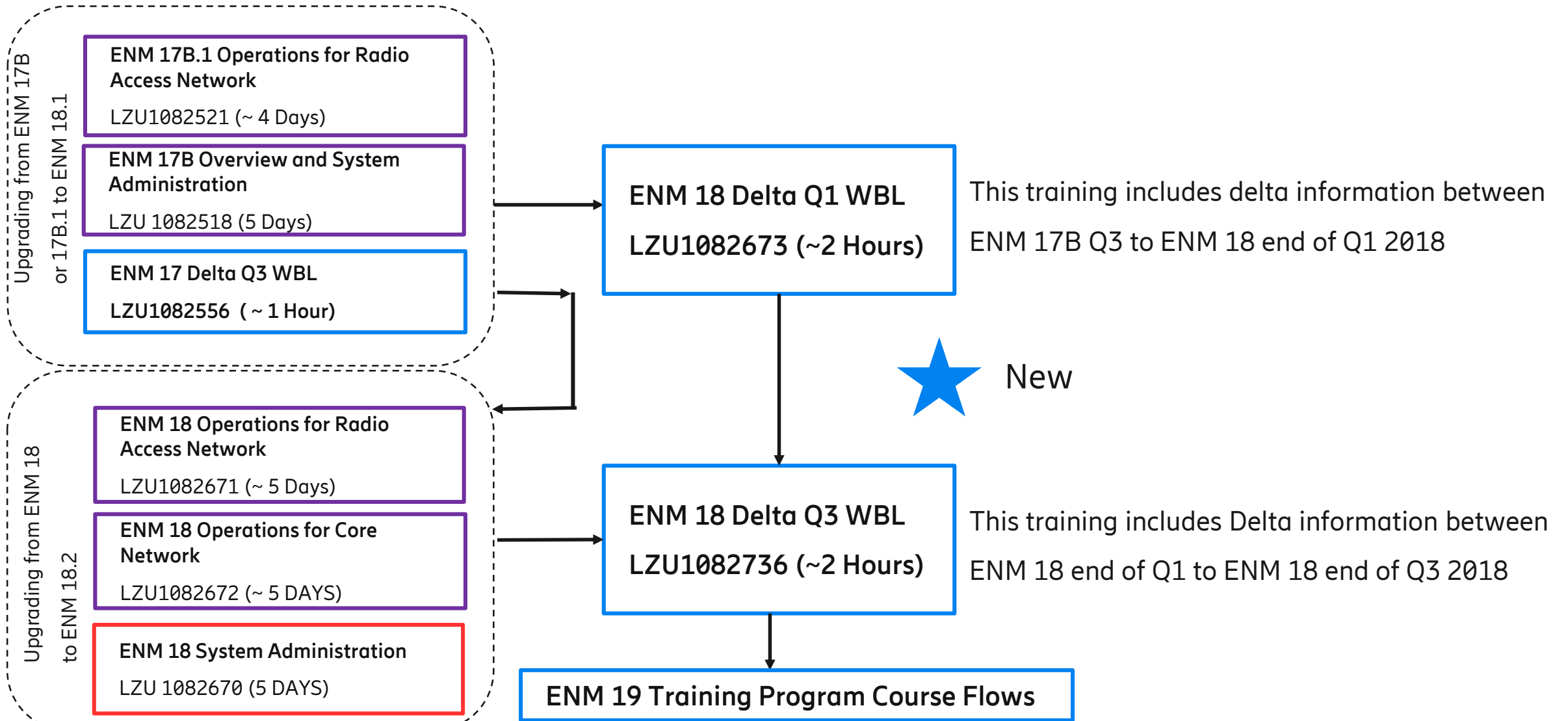

NMaaS Learning Levels & Areas



Technical Fundamentals

NMaaS/ENM Network Operations and Administration

- Offered towards Ericsson Network Manager as a Service customers

NMaaS/ ENM Network Operations and Administration



General understanding of telecom network and
OSS System recommended



ENM Technical Fundamentals WBL
(Choose from Fundamental section as needed)



NMaaS/ENM Network Operations
and Administration
LZU1082743 (~ 5 Days)



New

Pre-requisite

- › Training suitable for Ericsson Network Manager as a Service offer
- › This Training is provided upon mandatory LS Consultation followed by analysis of Job Role based tasks based on as a service agreements
- › The consultation is offered by respective Market Area LS by engaging with the customer project

ENM 18 Learning Portfolio Summary

Web Based Learning Offers



LIST OF COURSES	LZU NUMBER	LEARNING SITUATION	SESSION DURATION
An Overview of ENM for Classical OSS Users	LZU1082519	WBL	~4 hours
An Overview of ENM for Classical SO EM	LZU1082564	WBL	~4 hours
Overview of ENM Application on Cloud	LZU1082563	WBL	~2 hours
ENM 18 Delta Q1	LZU1082673	WBL	~ 2 hours
ENM 18 Delta Q3	LZU1082736	WBL	~ 2 hours
ENM Use Cases	LZU1082674	WBL	~ 2 hours
Auto-provisioning in ENM	LZU1082582	WBL	~ 1 hour

ENM 18 Learning Portfolio Summary



LIST OF COURSES	LZU NUMBER	LEARNING SITUATION	DURATION
ENM 18 Operations for Radio Access Network Blended Training on ENM for RAN	LZU1082671	ILT	~ 5 Days
ENM 18 Operations for Core Network	LZU1082783	BLD	
ENM 18 Operations for Core Network	LZU1082672	ILT	~ 3 Days
ENM 18 Operations Transport	LZU1082737	ILT	~ 5 Days
ENM 18 System Administration	LZU1082670	ILT	~ 5 Days
ENM Open Stack Cloud System Administration	LZU1082738	ILT	~ 4 Days
Python in ENM	LZU1082735	ILT	3 Days
VNF LCM in ENM	LZU1082742	ILT	2 Days
Fault Management in ENM using FMX	LZU1082744	ILT	5 Days
NMaaS/ENM Network Operations and Administration	LZU1082743	ILT	~ 5 Days

Learning Levels & Areas



Technical Fundamentals

ENM Radio Access Network

ENM Core Network

ENM Transport

ENM System Admin

ENM Delta

VNF LCM in ENM

Python in ENM

FMX in ENM

Case Study : Typical Competence Flow for Operations and System Administration

Case Study : Customer ENM project

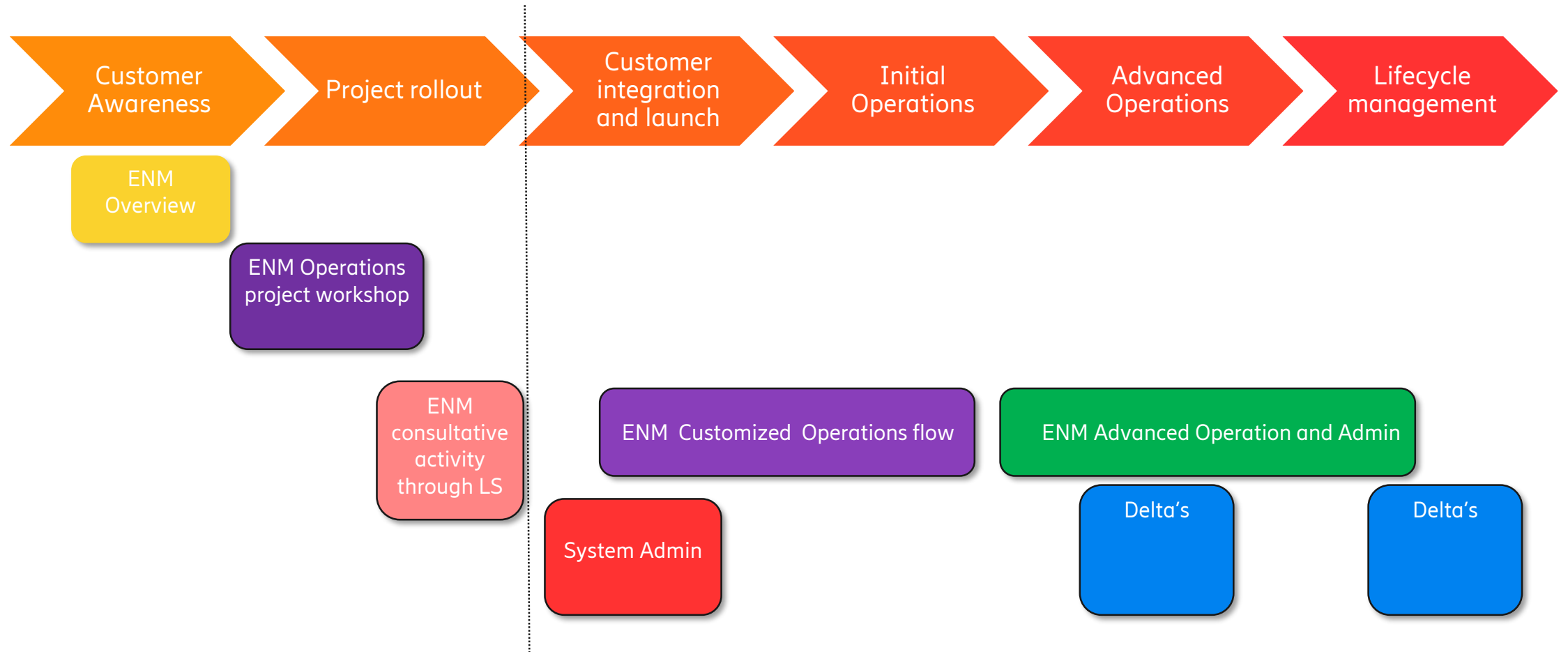

Typical Competence Flow

Customer ENM Operations RAN

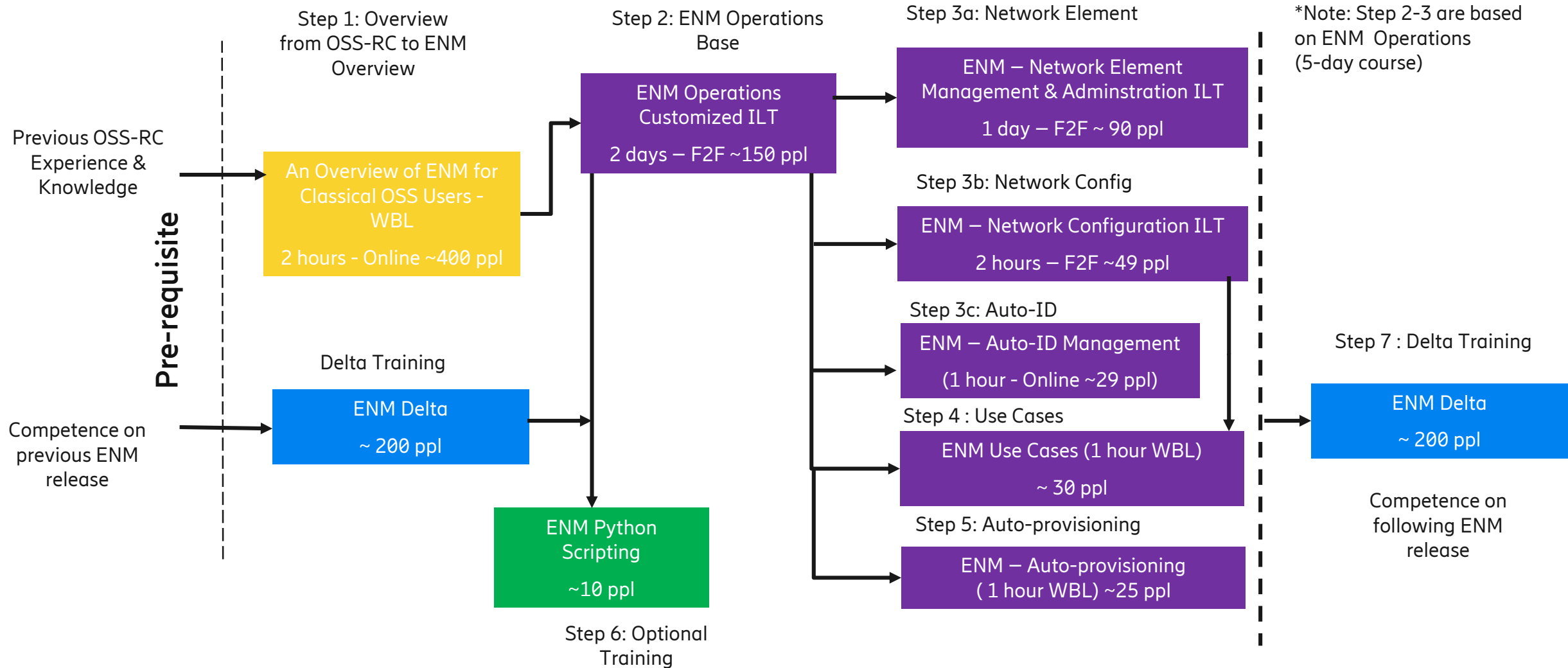

Typical Competence Flow Customer ENM System Administration

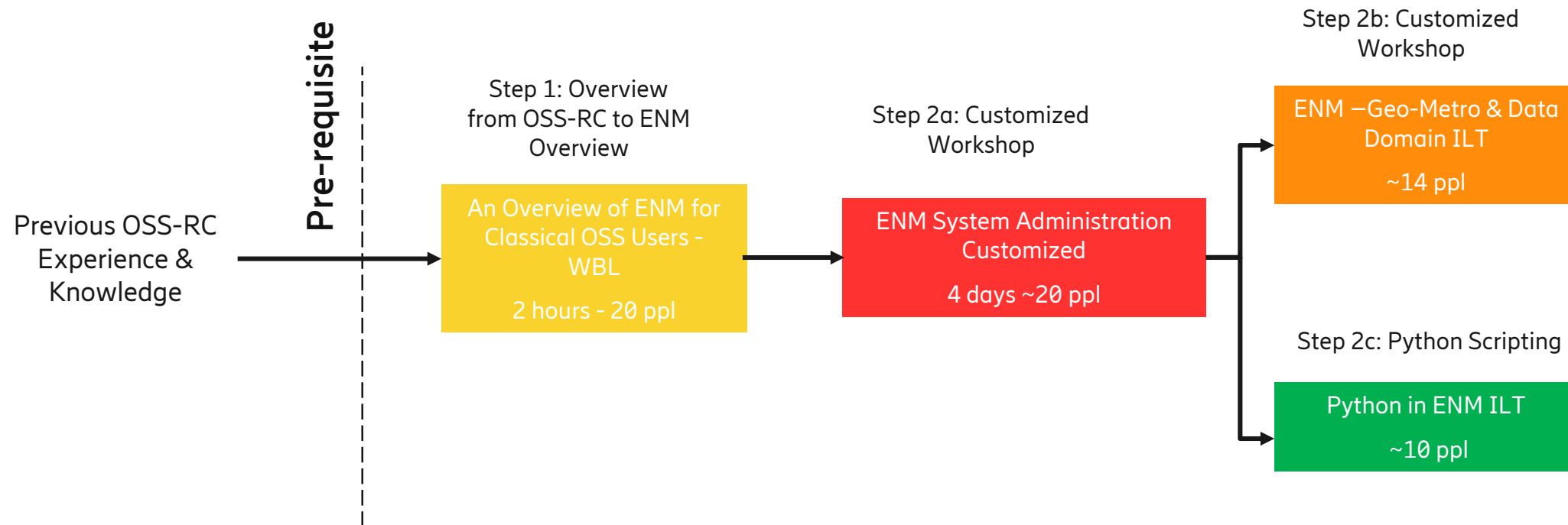

Contact and Further Information



- Find out more about Ericsson Learning Services:

<https://www.ericsson.com/ourportfolio/digital-services-services/learning-services>

- For further information about the courses in the training portfolio and the course descriptions:

https://www.ericsson.com/ourportfolio/digital-services-services/training-programs?nav=fgb_101_117

